

SMALLER, FASTER, LIGHTER
**COMPACT MEASURES
HUGE POWER**

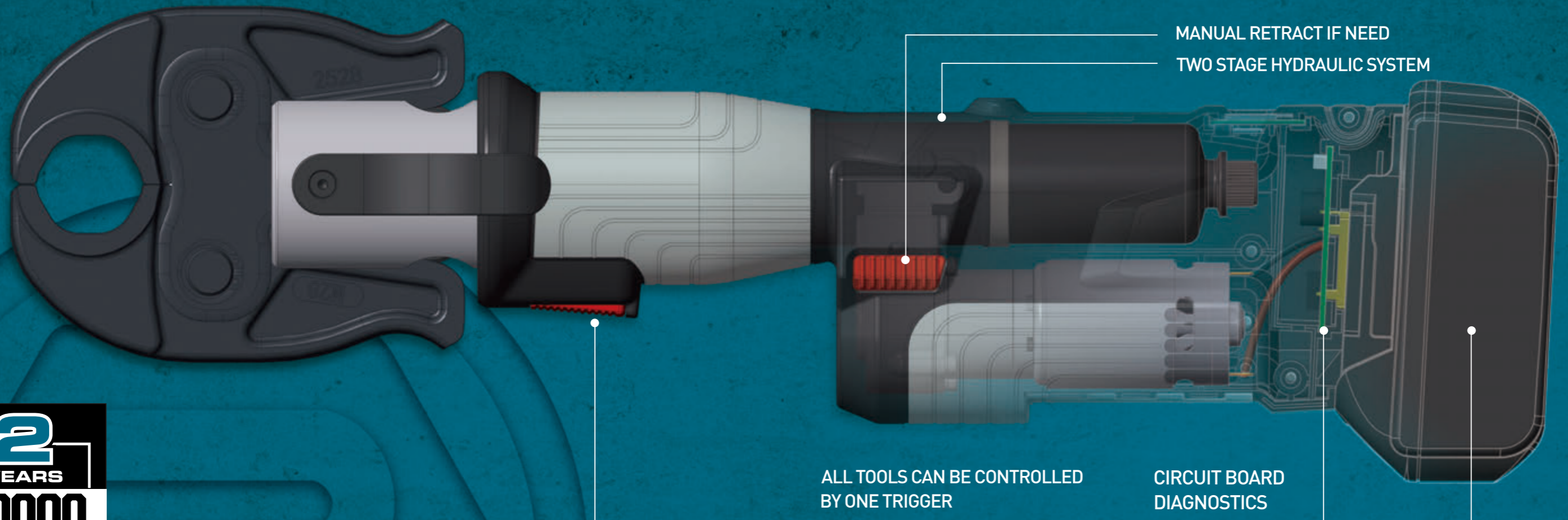

2
YEARS
30000
CYCLES
PZ SERIES
BATTERY POWERED
PRESS TOOL

THE RIGHT TOOL FOR YOUR NEEDS

- **CIRCUIT BOARD DIAGNOSTICS**
Alert you when the battery is low or the tool is too hot or cold
- **OLED DISPLAY**
 - Easy reading on
 - Battery Percentage
 - Pressing Times
 - Fault Code
 - Maintenance Note

ALL TOOLS CAN BE CONTROLLED BY ONE TRIGGER

CIRCUIT BOARD DIAGNOSTICS

HIGH PERFORMANCE 18V Li-ion Battery

- **180° SWIVELLING BARREL**
Easy access to connections
- **TWO STAGE HYDRAULIC SYSTEM**
Hydraulic Ram Output provides more force for reliable connection
- **ERGONOMIC DESIGN**
With light weight and inline grip, easily work overhead and in tight spaces.
- **SERVICE INTERVAL: 30000 Cycles**

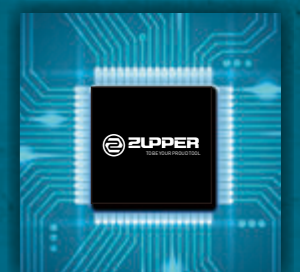

CIRCUIT BOARD DIAGNOSTICS
Alert you when the battery is low or the tool is too hot or cold

SMALLER, FASTER, LIGHTER
**COMPACT MEASURES
HUGE POWER**

PZ-1930

BATTERY POWERED PRESS TOOL
precise pressing with lighter body

- 15-28mm(1/2"-1")Stainless Pipe
- 15-35mm(1/2"-1 1/2")Copper Pipe
- 16-32mm PEX & Multi-layer Pipe

The PZ-1930 is the newest addition to the mini press tool with in-line grip, it is efficient and reliable way to join copper, stainless steel and PEX&Multi-layer Pipe.



COPPER PIPE



MULTI-LAYER COMPOSITE PIPE



PEX PIPE



STAINLESS STEEL PIPE



SPECIFICATIONS

| | | | |
|-------------------------|---|-------------------|--|
| Capacity: | 12-28mm(1/2"-1") Stainless steel pipe, 12-35mm(1/2"-1") Copper pipe, 12-32mm PEX&Multi-layer pipe | Battery: | 18V Li-ion 2.5Ah |
| Output: | 19KN | Battery Charger: | AC 100-240V |
| Stroke: | 30mm | Charging Time: | Approx. 50mins |
| Oil capacity: | Approx. 60ml | Service Interval: | Service Interval: 30000cycles |
| Crimping Cycle Time: | 2-4S | Weight: | Approx.2.0kgs (tool with battery) Approx. 3.5kgs(tool with battery and jaw) |
| Crimping Cycles/charge: | 180cycles (DN 20 Stainless Steel) | Tool Size: | Tool Size: 363×120×75mm |

| MODEL NO. | DESCRIPTION | Weight (KGS) | Standard Pack |
|-------------|---|--------------|---------------|
| PZ-1930 | PZ-1930 Battery Press Tool Kit without jaws | 6.10 | 1pc |
| ACCESSORIES | 18V, 2.5 Ah Li-Ion Batteries | 0.35 | 2pcs |
| | Charger | 0.70 | 1pc |
| | Plastic case | 2.90 | 1pc |
| | Sealing ring of cylinder: | | 1set |
| | Sealing ring of safety valve: | | 1set |

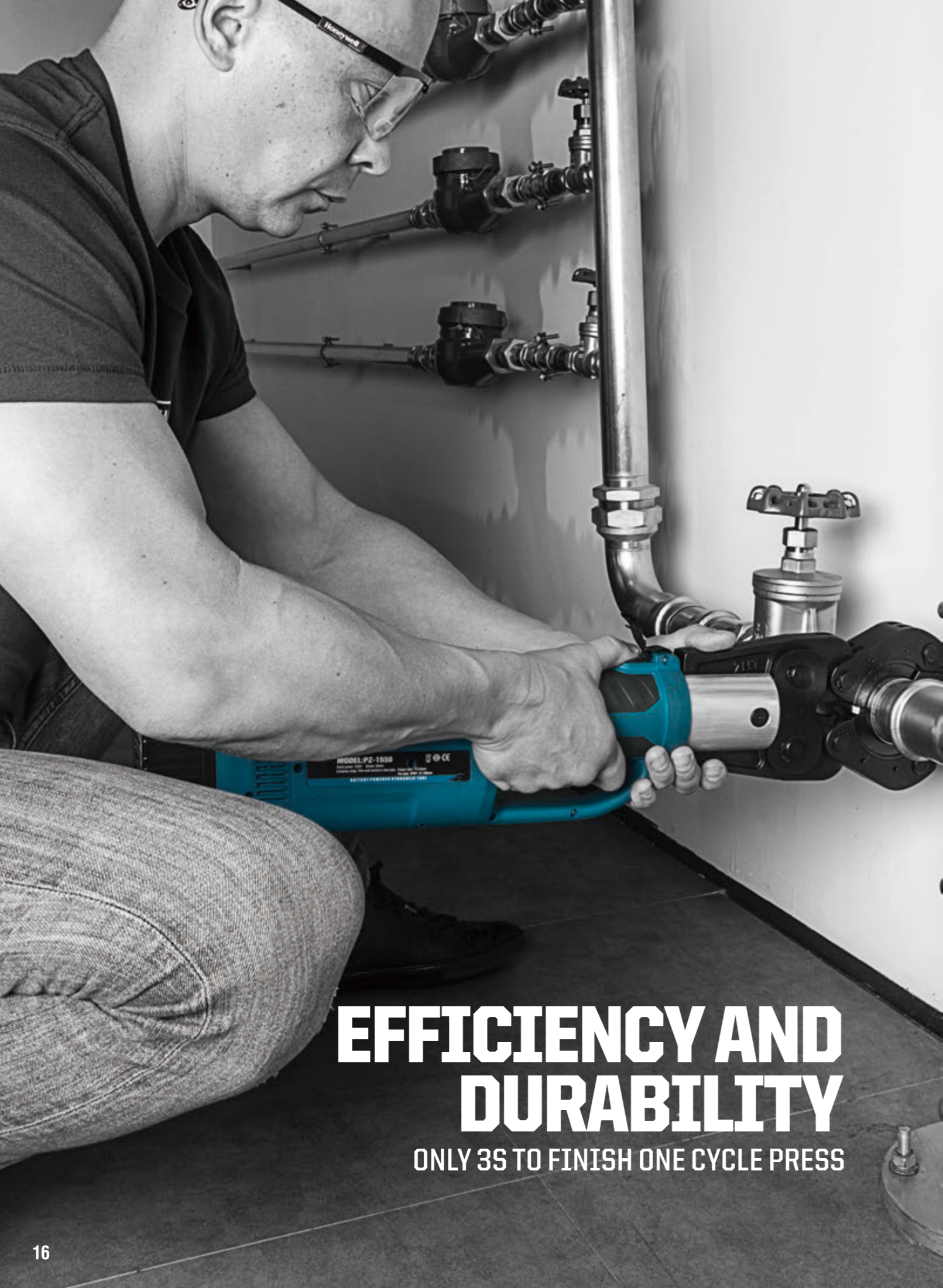

EFFICIENCY AND DURABILITY
ONLY 3S TO FINISH ONE CYCLE PRESS

PZ-1550

BATTERY POWERED PRESS TOOL

Efficiency and Durability

- Battery press tool with in-line grip.
- SPEED UP 20% compare with old type. Only 3~4.5S to finish one cycle press
- The tool comes standard with two 18V,4.0Ah Lion-batteries and one charger. It can achieve over 350 cycles per charger.
- Motor drivers, Micro-computer control system, OLED screen and double valve hydraulic system.



COPPER PIPE



MULTI-LAYER COMPOSITE PIPE



PEX PIPE



STAINLESS STEEL PIPE



3~4.5s
PER CYCLE TIME



SPECIFICATIONS

| | | | |
|---------------|--|-------------------|---|
| Capacity: | 12-54mm(1/2"-2") for stainless steel pipe 12-108mm(1/2"-4") for PEX,Multi-layer and copper pipe | Battery: | 18V Li-ion 4.0Ah |
| Output: | 32KN | Battery Charger: | AC 100-240V |
| Stroke: | 40mm | Charging Time: | Approx. 80mins |
| Cycle Time: | Approx. 3-4.5 seconds | Service Interval: | 30000cycles |
| Oil capacity: | 115ml | Weight: | Approx.3.9kgs (tool with battery) Approx.6.1kgs(tool with battery and jaw) |
| | | Tool Size: | 450x81x128mm |

PZ-1550 Battery Press Tool Kit

| MODEL NO. | DESCRIPTION | Weight(kgs) |
|--------------|---|-------------|
| PZ-1550 | PZ-1550 Battery Press Tool Kit without jaws | 9.20 |
| | Battery, 18V, 4.0Ah Li-Ion | 0.60 |
| ACCESSORRIES | Charger | 0.70 |
| | Plastic case | 4.10 |